

Sheridan MEDICINE CABINET

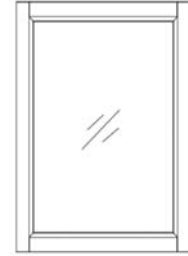

FEATURES/TYPICAL SPECIFICATIONS

- Surface-Mounted Installation
 - Two Integral Mounting Bars
 - Pre-Drilled Mounting Holes (4 typical)
- Housing/Body is Panel Style Construction (WD)
 - Particle Board Construction with PVC Laminate
 - MDF Back Panel
 - Dowel/Glue and Metal Fastener Construction
- Solid Wood Frame with Miter Cut Corners
 - Solid Poplar with Espresso Finish (ESP02)
- Mirror Door (1 typical)
 - Reversible for left-hand or right-hand door swing
 - Framed 3MM thick mirror on door front
 - Door back panel is MDF with espresso PVC Laminate
- Magnet in espresso plastic cover fastened to cabinet body aligns to metal striker plate on the door (1 typical)
- Satin nickel full wrap hinges, (2 typical) (HG24)
- Shelf, particle board with espresso PVC laminate (1 typical)
 - Fixed, non-removable (FX)
- Includes Mounting Hardware

Finishes:

Housing: ESP02-Espresso

Mirror: Flat Mirror

Frame: ESP02-Espresso

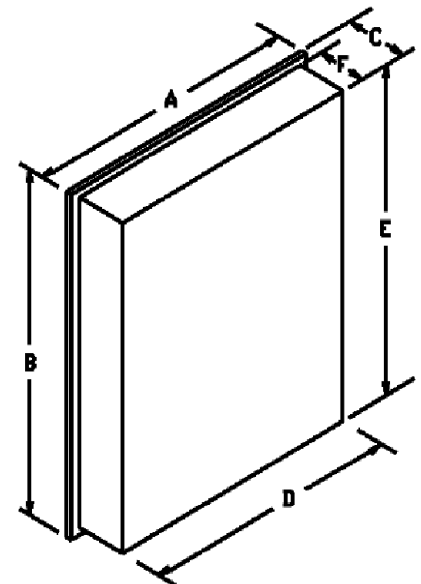

CARB 93120 Phase 2 Compliant for Formaldehyde

		Dimensions In Inches					
Model #	Description	A	B	C	D	E	F
780989	MEDCAB 1DR 15X19 FMLS WD	15	19	4¾	13-13/16	17-13/16	4

REFERENCE	QTY.	REMARKS	Project
			Location
			Architect
			Engineer
			Contractor
			Submitted by
			Date

* All models and material specifications are subject to change or withdrawal without notice.