

Granville MEDICINE CABINET

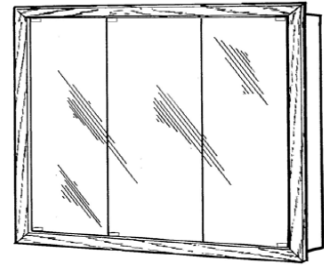

FEATURES/TYPICAL SPECIFICATIONS

- Surface-Mounted Installation
 - Two Integral Mounting Bars
 - Pre-Drilled Mounting Holes (4 typical)
- Housing/Body is Panel Style Construction (WD)
 - Particle Board Construction with PVC Laminate
 - MDF Back Panel
 - Dowel/Glue & Tongue & Groove Construction
- Solid Wood Frame with Miter Cut Corners
 - Solid Poplar with Classic White Finish (PT02)
 - The frame is attached to the top, bottom, and side panels of housing by glue and tongue in groove or glue and wooden dowels as a minimum.
- Mirror Doors (3 typical)
 - Right-hand swing (2 typical) and left-hand swing (1 typical)
 - Polished Edges, 4 sides
 - Laminated Protective Mirror Backing
- Shelves, particle board with white PVC laminate (2 typical)
 - Fixed, non-removable (FX)
- Chrome Finish Glass Pivot Hinges, set of two (3 sets typical) (HG03)
- Spring-loaded, white magnetic touch latch fastened to cabinet body aligns to chrome finished metal plate on the mirror door back (3 typical)
- Includes Mounting Hardware

Finishes:

Housing: PT02-Classic White
 Mirror: POL1-Polished Edge
 Frame: PT02-Classic White

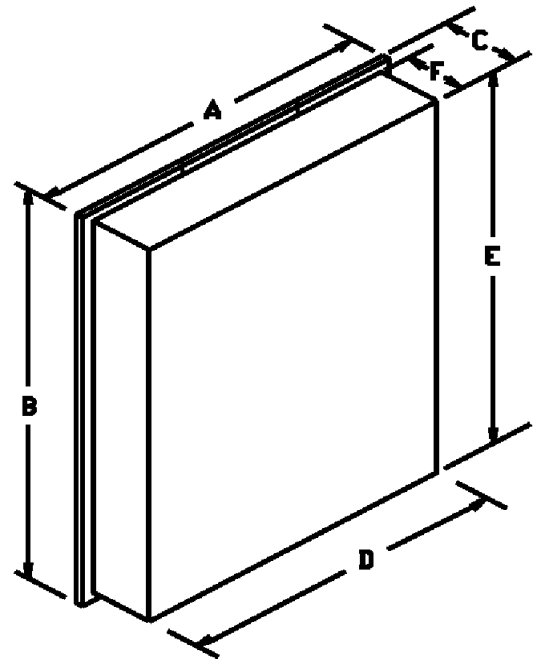

CARB 93120 Phase 2 Compliant for Formaldehyde

| | | Dimensions In Inches | | | | | |
|---------|--------------------------|----------------------|----|-------|---------|---------|---|
| Model # | Description | A | B | C | D | E | F |
| 740613 | MEDCAB 3DR 48X30 FMLS WD | 48 | 30 | 4 3/4 | 46-7/16 | 28-3/16 | 4 |

| REFERENCE | QTY. | REMARKS | Project |
|-----------|------|---------|--------------|
| | | | Location |
| | | | Architect |
| | | | Engineer |
| | | | Contractor |
| | | | Submitted by |
| | | | Date |

* All models and material specifications are subject to change or withdrawal without notice.