

### Lighted MEDICINE CABINET

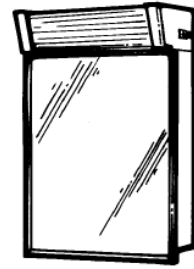

#### FEATURES/TYPICAL SPECIFICATIONS

- Surface Mount Installation
  - Pre-drilled mounting holes
- Formed and welded steel housing (WB/ST)
  - 24 gauge steel construction with white, heat cured, acrylic paint finish
- Framed mirror door
  - 2MM thick float glass mirror door front
  - Polished stainless steel frame with tab and screw closure (SS8)
  - 24 gauge steel door back with white, heat cured, acrylic paint finish
- 16" piano hinge with 90° stop welded to the door and mechanically fastened to the cabinet body (HG01) (1 typical)
- Magnetic catch in cabinet body flange aligns to stainless steel striker plate on the door (1 typical)
- Right-hand door swing
- Incandescent dual socket top light with plastic shade. Light box has bright stainless trim strips on both sides. (Uses two 60 watt maximum, medium base, 120V bulbs (I60A) - bulbs not included)
- Grounded convenience outlet and on/off switch located at top of cabinet on right side
- High-impact polystyrene shelves (2 typical)
  - Fixed shelves removable (FX2)
- Includes installation hardware
- Pallet Quantity = 24 units

#### Finishes:

Housing: PT01-Basic White  
 Mirror: Flat Mirror  
 Frame: SS8-Polished Stainless Steel

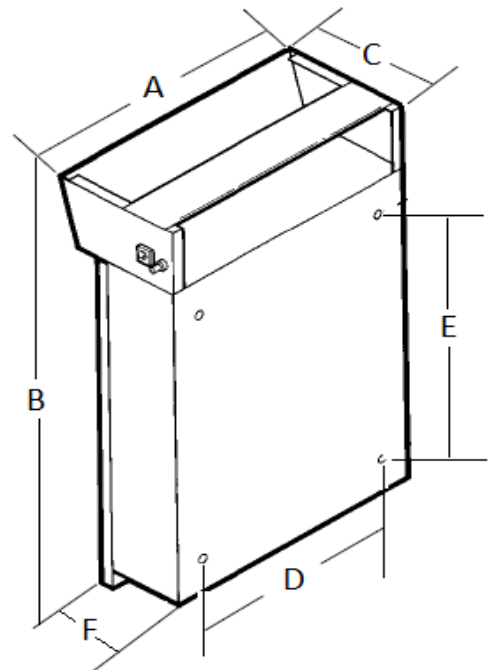

		Dimensions In Inches					
Model #	Description	A	B	C	D	E	F
555IL	MEDCAB 1DR 16X24 SS8 WB/ST	16	24	8	9 <sup>3</sup> / <sub>4</sub>	13 <sup>3</sup> / <sub>8</sub>	5 <sup>1</sup> / <sub>2</sub>

REFERENCE	QTY.	REMARKS	Project
			Location
			Architect
			Engineer
			Contractor
			Submitted by
			Date

\* All models and material specifications are subject to change or withdrawal without notice.