

Styleline MEDICINE CABINET

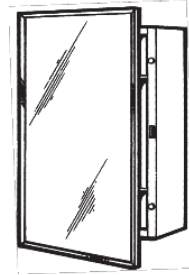

FEATURES/TYPICAL SPECIFICATIONS

- Surface Mount Installation
 - Pre-drilled mounting holes spacing: y = 11.500" and x = 11.0" center-to-center
- Formed and welded steel housing (WB/ST)
 - 24 gauge steel construction with white, heat cured, acrylic paint finish
- Frameless mirror door
 - 5/32" float glass mirror door front with polished edges, 4 sides (POL1)
 - 30 gauge steel door back with white, heat cured, acrylic paint finish
- 16" piano hinge welded to the door and mechanically fastened to the cabinet body (HG01) (1 typical)
- Magnetic catch in cabinet body flange aligns to stainless steel striker plate on the door (1 typical)
- Reversible for left-hand or right-hand door swing
- 26 gauge galvanized steel shelves with white, heat cured, enamel paint finish (2 typical)
 - Fixed shelf — removable (FX2)
- Mounting hardware included
- Pallet quantity = 36 units

Finishes:

Housing: PT01—Basic white
 Mirror: POL1—Polished Edge
 Frame: Frameless

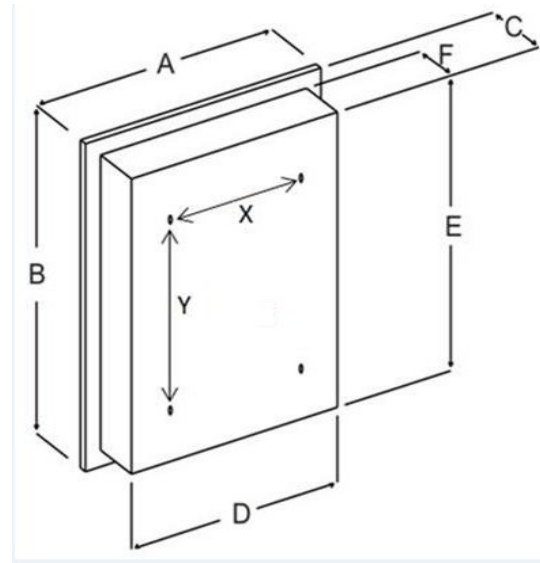

Model #	Description	Dimensions In Inches					
		A	B	C	D	E	F
454SM	MEDCAB 1DR 16X22 PPE WB/ST ST/FX2	16	22	5	15½	21½	4½

REFERENCE	QTY.	REMARKS	Project
			Location
			Architect
			Engineer
			Contractor
			Submitted by Date

* All models and material specifications are subject to change or withdrawal without notice.