

# FULL MORTISE RESIDENTIAL HINGE

Template No. T399

SIZE: 4 x 4  
(101.60 x 101.60)

No.	REVISION	BY	DATE
3	ECO CT02051	RM	1-30-03
4	PART NUMBER ADD	MRJ	12-27-06

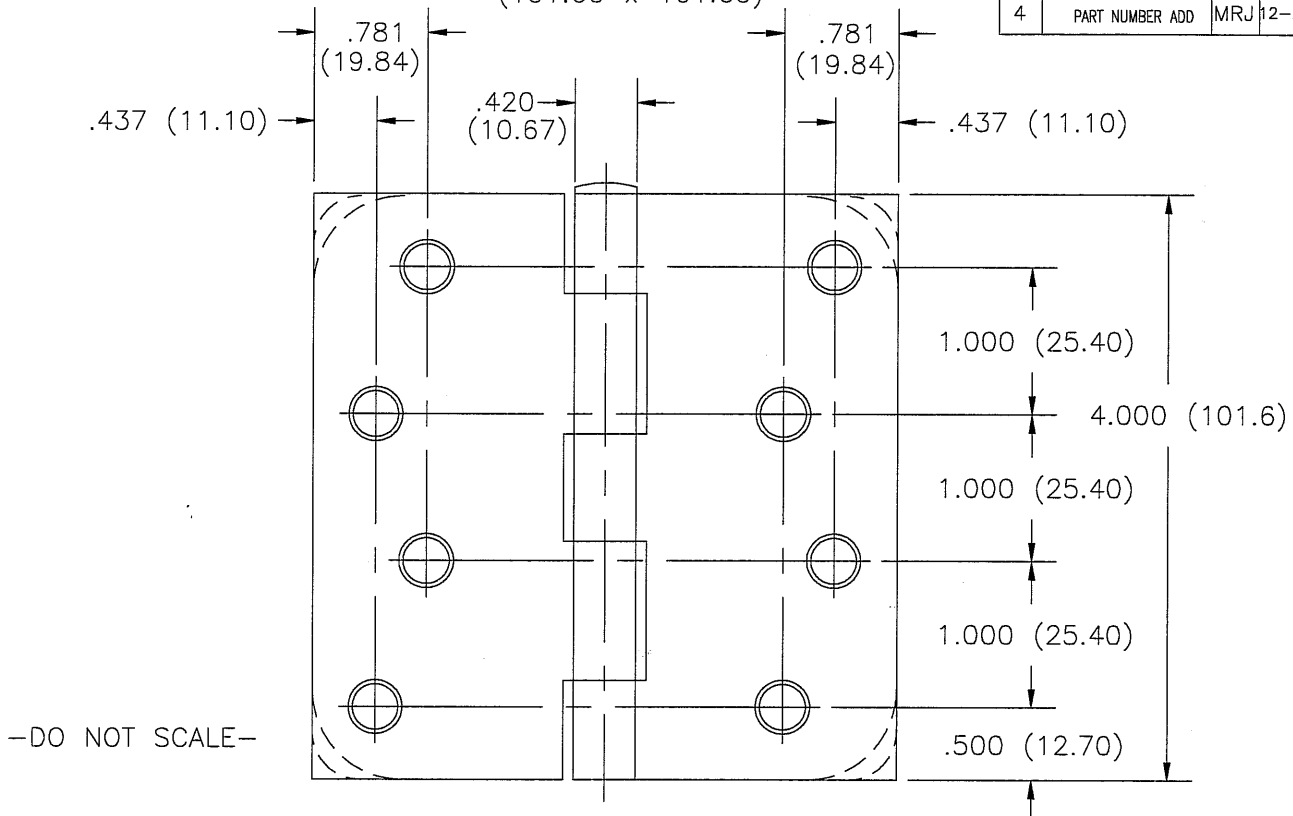

CATALOG NUMBER			
STEEL HINGES	NON-FERROUS HINGES	TYPICAL CORNER RADII	METAL GAUGE
	1541	SQUARE	.085 (2.16)
1741		SQUARE	.085 (2.16)
1743		SQUARE	.085 (2.16)
1746		SQUARE	.085 (2.16)
BB1541		SQUARE	.085 (2.16)
BB1741		SQUARE	.085 (2.16)
	RC1541	1/4 (6.35)	.085 (2.16)
RCBB1541		1/4 (6.35)	.085 (2.16)
RC1741		1/4 (6.35)	.085 (2.16)
RCBB1741		1/4 (6.35)	.085 (2.16)
7741		1/4 (6.35)	.085 (2.16)
RC1743		1/4 (6.35)	.085 (2.16)
RC1746		1/4 (6.35)	.085 (2.16)

CATALOG NUMBER			
STEEL HINGES	NON-FERROUS HINGES	TYPICAL CORNER RADII	METAL GAUGE
	RC1542	5/8 (15.88)	.085 (2.16)
RC1641		5/8 (15.88)	.085 (2.16)
8641		5/8 (15.88)	.085 (2.16)
RC1841		5/8 (15.88)	.085 (2.16)
RC1842		5/8 (15.88)	.085 (2.16)
8741		5/8 (15.88)	.085 (2.16)
RC1843		5/8 (15.88)	.085 (2.16)
RC1846		5/8 (15.88)	.085 (2.16)
8744		1 LEAF SQUARE/ 1 LEAF 5/8 (15.88)	.085 (2.16)
RC1847		1 LEAF SQUARE/ 1 LEAF 5/8 (15.88)	.085 (2.16)
1848		1 LEAF SQUARE/ 1 LEAF 5/8 (15.88)	.085 (2.16)
8746		1 LEAF SQUARE/ 1 LEAF 5/8 (15.88)	.085 (2.16)
1816		1 LEAF SQUARE/ 1 LEAF 5/8 (15.88)	.085 (2.16)
BB1816		1 LEAF SQUARE/ 1 LEAF 5/8 (15.88)	.085 (2.16)
1817		1 LEAF SQUARE/ 1 LEAF 5/8 (15.88)	.085 (2.16)
BB1817		1 LEAF SQUARE/ 1 LEAF 5/8 (15.88)	.085 (2.16)
1818		1 LEAF SQUARE/ 1 LEAF 5/8 (15.88)	.085 (2.16)
1819		1 LEAF SQUARE/ 1 LEAF 5/8 (15.88)	.085 (2.16)
	1543	1 LEAF SQUARE/ 1 LEAF 5/8 (15.88)	.085 (2.16)
	BB1543	1 LEAF SQUARE/ 1 LEAF 5/8 (15.88)	.085 (2.16)

Hager testing conforms to ANSI-A156.1.

HAGER RESERVES THE RIGHT TO MAKE DESIGN CHANGES WITHOUT NOTICE. CALL HAGER ENGINEERING AT 1-800-325-9995 FOR LATEST REVISION DATE OF TEMPLATE.



**HAGER COMPANIES**  
139 VICTOR STREET  
P.O. BOX 12300  
ST. LOUIS, MISSOURI 63157-0300

Template No. T399