

## 011/021 Series Models

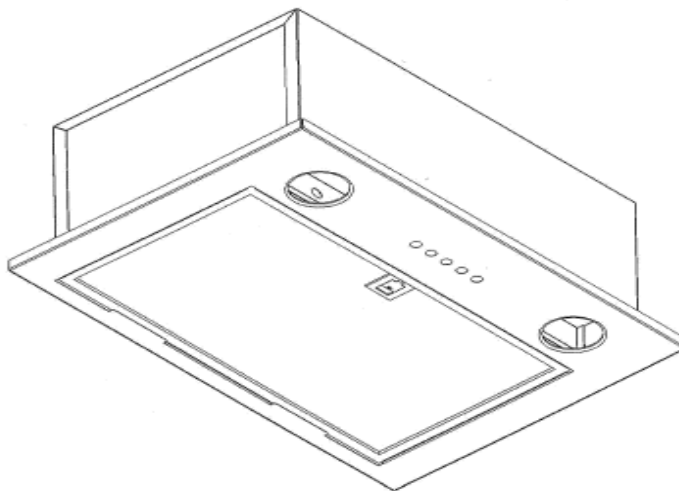

### RANGE HOOD LOCATION

1. The range hood must be installed just above the cooktop.
2. The minimum distance from the cooking surface to the bottom of the range hood must be 24”.

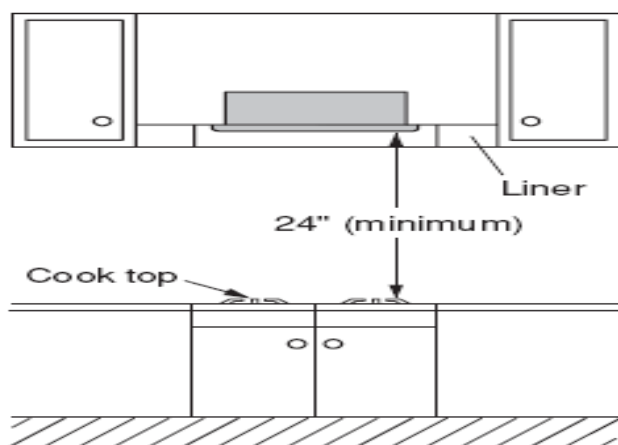

3. The total weight of the 011/021 range hood unit is 18 lbs. (8 kg)
4. Power requirements are:

011: AC120 V, 60 Hz, 1.7 Amp

021: AC120 V, 60 Hz, 2.2 Amp



#### CAUTION:

- Check that the hood is correctly installed, since incorrect installation could result in the detachment of the range and that unit could fall.
- To protect hands from injury, wear working gloves when installing the range hood.

# ACCESSORIES



Screw M5x30  
Four (4) pieces



Nut with plate  
Four (4) pieces



7" Round  
Damper

# DIMENSIONS

Unit: inch

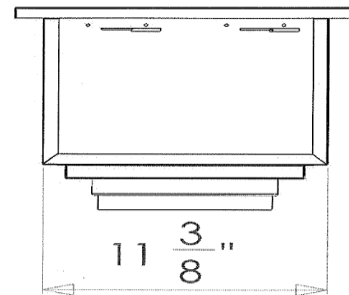
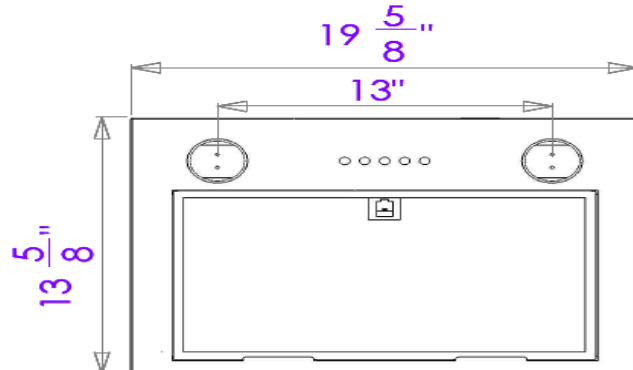
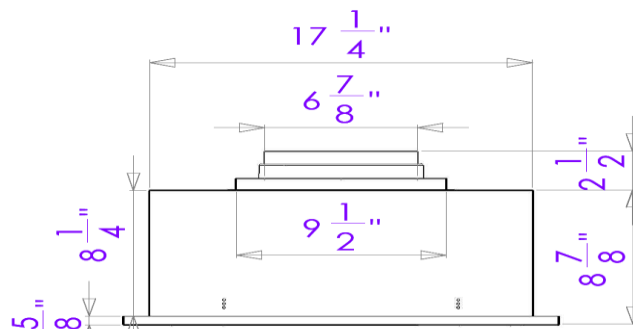
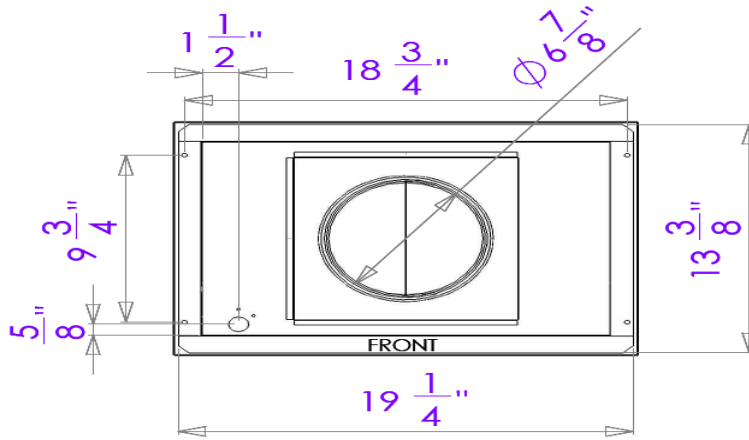

# SAFETY INSTRUCTIONS

Before installation and operation, read these instructions carefully and use this product only in the manner described by the manufacturer in the operation manual.

The instructions shown below are used to alert you to potential personal injury and property damage hazards.

There are three hazard classifications based on potentially dangerous situations.

Obey all safety instructions that show these symbols to avoid possible injury, death and property damage.

 **WARNING:** WARNING indicates a potentially hazardous situation which, if not avoided, could result in death or serious injury.

 **CAUTION:** CAUTION indicates a potentially hazardous situation which, if not avoided, may result in minor or moderate injury.



**CAUTION:** CAUTION indicates used without the safety alert symbol indicates a potentially hazardous situation which, if not avoided, may result in property damage.

*NOTE: The safety instructions are explained with the following pictographic symbols.*

 means prohibition. It indicates actions, if any, that must not be done.

 means forcible execution. It indicates actions, if any, that must be done.

 **WARNING**

-  1. TO REDUCE THE RISK OF FIRE, ELECTRONIC SHOCK, OR INJURY TO PERSONS, OBSERVE THE FOLLOWING:
- Use this unit only in the manner indicated by the manufacturer. If you have questions, contact the manufacturer.
  - Before servicing or cleaning the unit, switch power off at service panel and lock the service disconnecting means to prevent power from being switched on automatically. When the service disconnecting means cannot be locked, securely fasten a prominent warning device, such as a tag, to the service panel.
-  2. To reduce the risk of fire or electric shock, do not use this product with any solid-state speed control device.
-  3. TO REDUCE THE RISK OF FIRE, ELECTRIC SHOCK, OR INJURY TO PERSONS, OBSERVE THE FOLLOWING:



- Installation work and electrical wiring must be done by a qualified person(s) in accordance with all applicable codes and standards, including fire-rated construction.
  - Sufficient air is needed for proper combustion and exhausting of gases through the flue (chimney) of fuel burning equipment manufacturer's guidelines and safety standards such as those published by the National Fire Protection Association (NFPA), and The American Society for Heating, Refrigeration and Air Conditioning Engineers (ASHRAE), and the local code authorities.
  - When cutting or drilling into wall or ceiling, do not damage electrical wiring and other hidden utilities.
  - Ducted fan must always be vented to outdoors.
4. TO REDUCE THE RISK OF FIRE, USE ONLY METAL DUCTWORK.
  5. This unit must be grounded.
  6. Check that the hood is correctly installed, since incorrect installation could result in the range hood becoming detached and falling off.
  7. Connect only to an AC120 Volt power source or the range hood could result in fire, electric shock, and damage.

 **CAUTION**

1. For general ventilating use only. Do not use to exhaust hazardous or explosive material and vapors.
2. To reduce the risk of fire and to properly exhaust air, be sure to duct air outside. Do not vent exhaust air into spaces within walls, ceilings or into attics, crawl spaces or garages.
3. Read specification label on this product for further information and requirements.
4. Use only for the purpose of kitchen ventilation.
5. Do not install this range hood in the bathroom or in other wet rooms since electrical shock and damage may result.
6. Fasten the filter and other parts securely. Incorrect attachment may result in personal injury or property damage.
7. Keep your hands and other objects away from the fan while it is in motion. The range hood may injure you or damage itself.

# PREPARATION



## WARNING:

- If the range hood is not installed properly, it could become detached and fall.
  - Ensure that the metal duct does not touch other metal housing materials, otherwise fire or electric shock could result.
1. According to the conditions where the range hood is installed, determine whether it will discharge vertically or horizontally (7" Round duct). For vertical or horizontal discharge, run duct work between the hood location and a roof cap or wall cap. For the best result in either direction, use a minimum number of transitions and elbows. Be sure to attach a roof cap or wall cap to avoid water leakage.

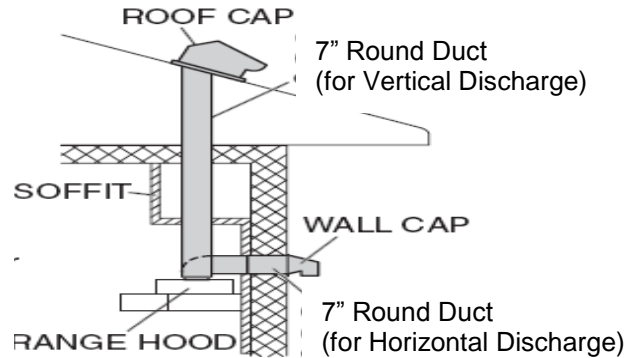

2. The range hood unit must be mounted to a liner which has the dimensions. Install the liner securely after checking that the opening size of the liner is the same as the figure below.

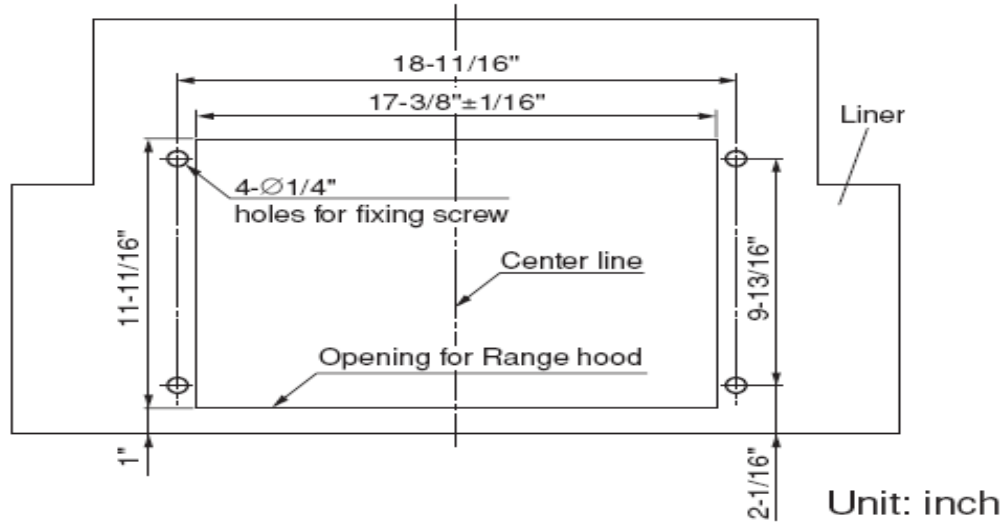

## CAUTION:

The liner should be installed tightly. If the liner installation is not correct, the range hood unit may become detached and fall off.



## WARNING – TO REDUCE THE RISK OF A RANGE TOP GREASE FIRE:

- a) Never leave surface units unattended at high settings. Boilovers cause smoking and greasy spillovers that may ignite. Heat oils slowly on low or medium settings.
- b) Always turn hood ON when cooking at high heat or when flambéing food (i.e. Crepes Suzette, Cherries Jubilee, Peppercorn Beef Flambé).
- c) Clean ventilating fans frequently. Grease should not be allowed to accumulate on fan or filter.
- d) Use proper pan size. Always use cookware appropriate for the size of the surface element.



## CONNECTING TO THE VENT PIPE

The 011/021 series ventilation modules come with a metal start collar. Attach the Start Collar to the duct with at least three equally spaced screws. Also apply duct tape, preferably the metal type. Some installations, (where the outside of this position of the duct is not accessible) will require the metal tape be applied on the *inside* of the duct.

## SPECIFICATION SHEET - 011

011 VMI, Inc. Blower unit, Individual Specifications Dated April 10, 2013

<b>Model</b>	<b>011 Stainless Steel Front Cover Panel*</b>
<b>Safety Standards</b>	C-UL-US Listed
<b>Dimensions</b>	
Front Panel	13 3/4" Deep x 19 3/4" Wide
Housing	11 3/8" Deep x 17 3/8" Wide x 8 1/4" High (with Damper, 10 3/4" High)
<b>Weight</b>	18 lbs
<b>Rated Voltage</b>	120 Volts
<b>Rated Frequency</b>	60 Hz
<b>Air Flow</b>	High Speed Operating 290 CFM Medium Speed Operating 210 CFM Low Speed Operating 150 CFM
<b>Noise Level</b>	High Speed Motor 7 Sones Medium Speed Motor 5 Sones Low Speed Motor 3 Sones
<b>Power Consumption Motor Only</b>	High Speed 120 Watts Medium Speed 90 Watts Low Speed 60 Watts
<b>Electric Motor</b>	Capacitor Motor, 3 Speeds
<b>Duct Dimension</b>	7" Round Duct
<b>Exhaust Direction</b>	Vertical Discharge from top, Horizontal with Elbow
<b>Installation</b>	At 4 places on flange of body, use screws and nut plates for mounting to Liner
<b>Materials</b>	Front Cover Panel - 304 Grade Stainless Steel, # 4 Brush Finish Housing Body - Electro-Galvanized steel Filters - Aluminum Mesh *Front Cover Panel Colors -Silver Metallic, White, Bisquit, Black
<b>Lighting</b>	(2) 50 watt MR16-GU10 Halogen Lamps
<b>Switches</b>	Mechanical Push Button 3 Speed with Off Motor Control Mechanical Push Button Light Control
<b>Electrical Wiring</b>	PVC, 18 AWG
<b>Accessories</b>	Damper, Nut Plates with screws
<b>Optional Parts</b>	Metal Liners, Rectangular, T-Shaped, Custom Sized
<b>Manual</b>	Installation/Operation Manual

## SPECIFICATION SHEET - 021

021 VMI, Inc. Blower unit, Individual Specifications Dated April 10, 2013

<b>Model</b>	<b>021 Stainless Steel Front Cover Panel*</b>
<b>Safety Standards</b>	C-UL-US Listed
<b>Dimensions</b>	
Front Panel	13 3/4" Deep x 19 3/4" Wide
Housing	11 3/8" Deep x 17 3/8" Wide x 8 1/4" High (with Damper, 10 3/4" High)
<b>Weight</b>	18 lbs
<b>Rated Voltage</b>	120 Volts
<b>Rated Frequency</b>	60 Hz
<b>Air Flow</b>	High Speed Operating 390 CFM Medium Speed Operating 290 CFM Low Speed Operating 180 CFM
<b>Noise Level</b>	High Speed Motor 7 Sones Medium Speed Motor 5 Sones Low Speed Motor 3 Sones
<b>Power Consumption</b>	High Speed 120 Watts
<b>Motor Only</b>	Medium Speed 90 Watts Low Speed 60 Watts
<b>Electric Motor</b>	Capacitor Motor, 3 Speeds
<b>Duct Dimension</b>	7" Round Duct
<b>Exhaust Direction</b>	Vertical Discharge from top, Horizontal with Elbow
<b>Installation</b>	At 4 places on flange of body, use screws and nut plates for mounting to Liner
<b>Materials</b>	Front Cover Panel - 304 Grade Stainless Steel, # 4 Brush Finish Housing Body - Electro-Galvanized steel Filters - Aluminum Mesh *Front Cover Panel Colors - Silver Metallic, White, Bisquit, Black
<b>Lighting</b>	(2) 50 watt MR16-GU10 Halogen Lamps
<b>Switches</b>	Mechanical Push Button 3 Speed with Off Motor Control Mechanical Push Button Light Control
<b>Electrical Wiring</b>	PVC, 18 AWG
<b>Accessories</b>	Damper, Nut Plates with screws
<b>Optional Parts</b>	Metal Liners, Rectangular, T-Shaped, Custom Sized
<b>Manual</b>	Installation/Operation Manual

# USE AND CARE



## WARNING!

Do NOT operate the blower/ventilator system without the filters in place, or with dirty, grease laden filters.



## OPERATING CONTROLS:

Always activate the ventilator or when using appliances. For the best performance, turn on the blower a few minutes before starting to cook to establish an airflow pattern within the room. Adjust the fan speed as needed. The left control adjusts the halogen lights and the right control adjusts the blower.



## ENERGY SAVING TIPS:

Eliminate air currents in the vicinity by shutting nearby windows and doors, turning off ceiling fans and adjusting the adjacent heating and air conditioning outlets if necessary. Place your largest pans on the rear burners whenever possible. Clean filters and grease laden surfaces often to improve efficiency. Always use lids on cookware to retain heat and moisture. Minimize the amount of liquid used to cook food. Select cookware of proper size, material and construction for the cooking task being performed.



## CARE & CLEANING:

Proper cleaning is necessary to maintain performance and appearance, while also ensuring safe operation. The frequency of cleaning should be according to the type and amount of cooking. Best results will be achieved by cleaning soiled components as soon as possible. Filters must be cleaned regularly. Remove the filter(s) by grasping the D ring on the filter front and pulling gently. Grasp the front of the filter to remove it. To reinstall the filter, place the back edge of the filter into the back filter bracket. Lightly push the filter toward the back of the liner while pressing the front side upwards into place.

The filters may be cleaned by hand washing in hot water using a mild detergent solution or by placing in an automatic dishwasher. Dry the filters before reusing.

**CAUTION: Most common scrubber type pads will scratch the liner.** If a commercially available stainless steel cleaner is used, it is important to read the labels for chlorine compounds. Chlorine is a corrosive substance. If these compounds are present, rinse thoroughly and dry with a soft lint-free cloth. Follow polish manufacturer's instructions. Always wipe stainless steel surfaces with the grain. Never wipe across the grain. After cleaning, reinstall the filters carefully.



## HALOGEN LIGHT BULBS:

Blowers are designed for MR16-GU10 50 watt halogen lamps. They can be purchased at most home or grocery stores, e.g., Lowe's, Home Depot, McCoy's, Menards or Ace True Value.

## ELECTRICAL CONNECTION

**IMPORTANT: Copy this page and the next for your electrical installer.**



**WARNING!** Ensure that the power supply is disconnected before proceeding. Verify that the power supply matches the ratings found on the appliance data label before proceeding. The complete appliance must be properly grounded at all times when electrical power is applied. Do not ground the appliance with the neutral (white) house supply wire. A separate ground wire must be utilized. Failure to complete electrical connections properly may result in damaged or non-functional systems. Follow instructions carefully to ensure proper installation.

It is the owner's responsibility to ensure that a qualified person performs the electrical connection of this appliance. The electrical installation, including minimum supply wire size, must comply with the National Electric Code ANSI/NFPA 70-1990 (or latest revision) and local codes and ordinances. A copy of this standard may be obtained from: National Fire Protection Association, 1 Batterymarch Park, Quincy, Massachusetts 02269-9101

**INSTRUCTIONS:** A 15 to 20 amp electrical service is recommended for proper electrical supply. Before determining, calculate amp ratings based on the product label found on the 011/021 series module. Always observe local building codes. Always use a dedicated circuit. Line load is calculated by adding the amperage of the halogen lights to the rated amperage of the ventilator. If the ventilator is rated in watts rather than amps, divide the watts by 120 and this will give you the amperage rating.



**CAUTION:** The neutral wire (usually white) for the ventilator must connect to the same neutral wire that comes from the electrical panel to the liner.

## Factory Installed Variable-Speed Wiring Details

Black	120 volt AC from electrical panel (usually black)
White	Neutral from electrical panel (white)
Green	Ground from electrical panel (usually green)

# Wiring Diagram

## 011/021 Series Models

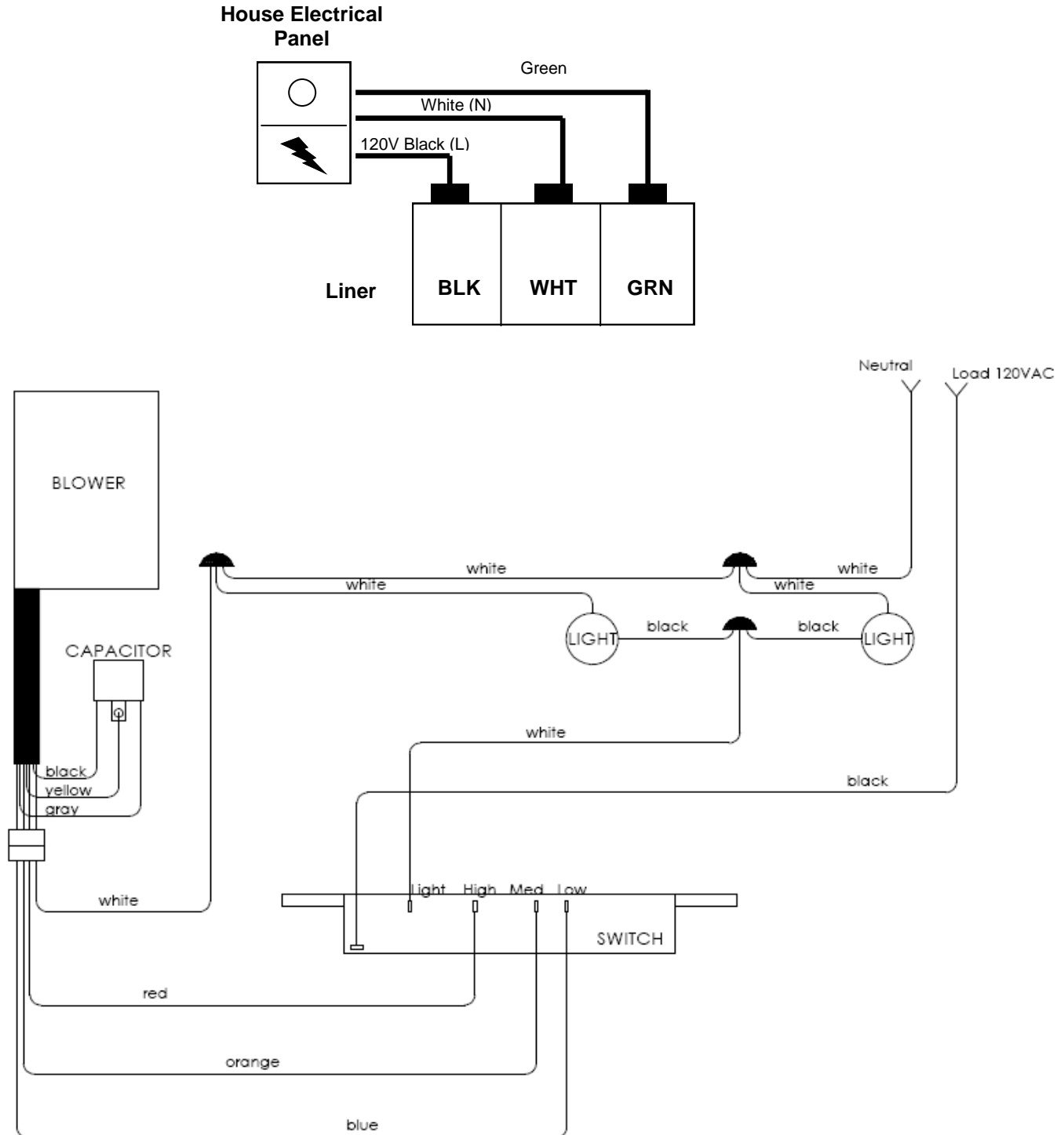





## WARRANTY

### Air-Pro™ Brand Ventilation Products

#### What is Covered

VMI Inc. warrants its **Air-Pro™** brand products to the original user, to be free of defects in materials and workmanship for three (3) years from the date of purchase.

VMI Inc., at its option, will repair or replace the complete unit or any defective component without charge providing that, if requested, the product or defective component is promptly returned, prepaid to the address below. This warranty may be voided if any unauthorized service, alterations or repairs are made to the product.

#### What is Not Covered

- Normal maintenance and service of any product that has been subject to misuse, negligence, accident or installation inconsistent with the recommended installation instructions
- Product used other than for normal in-home use or products used outside of the United States and Canada.
- Damage to the product caused by accident, fire, flood or other acts of God.
- Service calls to educate the customer in the proper use and care of the product, correct faulty installation, change fuses or reset breakers.

VMI Inc. disclaims and excludes any liability for implied warranties or for incidental or consequential damages wherever permitted by law. There are no implied warranties of merchantability or fitness for a particular use or purpose. This warranty gives you specific legal rights and you may also have other rights, which vary from state to state.

#### For Service

If you need service, contact Customer Service at the address or phone number below. Provide the model number, part identification and details of the problem. Proof of purchase must be provided.



VMI Inc.  
P.O. Box 2765 • Redmond, WA 98073  
Phone: 206-835-9880 • Fax: 206-835-9876  
[www.vmi-inc.net](http://www.vmi-inc.net)



Rev. 04/13

VMI, Inc.  
P.O. Box 2765  
Redmond, WA 98073  
Toll Free: 1-888-547-9880  
Phone: 206-835-9880 \*\*\*\* Fax: 206-835-9876

## 011/021 Série Modèles

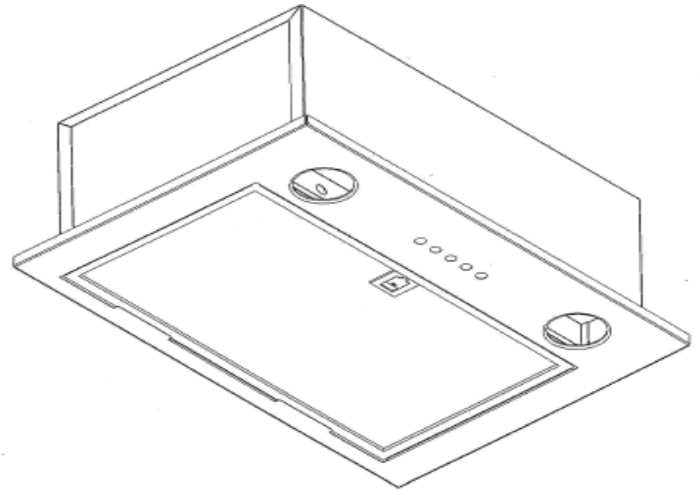

### GAMME EMPLACEMENT CAPOT

1. La plage du capot doit être installé juste au-dessus de la cuisinière.
2. La distance minimale de la surface de cuisson et le bas de la gamme du capot doit être de 24 ".

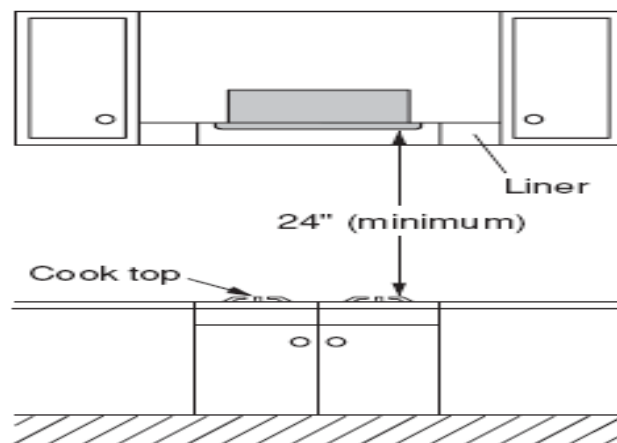

3. Le poids total du 011/021 de la hotte est de 18 lbs (8 kg)
4. Exigences d'alimentation sont les suivantes:

011: AC120 V, 60 Hz, 1.7 Amp

021: AC120 V, 60 Hz, 2.2 Amp

#### ATTENTION :

- Vérifier que le capot est correctement installé, car une mauvaise installation pourrait entraîner le détachement de la gamme et cette unité pourrait tomber.
- Pour protéger les mains contre les blessures, porter les gants de travail lors de l'installation de la gamme le capot.

# ACCESSORIES



**Screw M5x30**  
Four (4) pieces



**Nut with plate**  
Four (4) pieces



**7" Round Damper**

# DIMENSIONS

Unit: inch

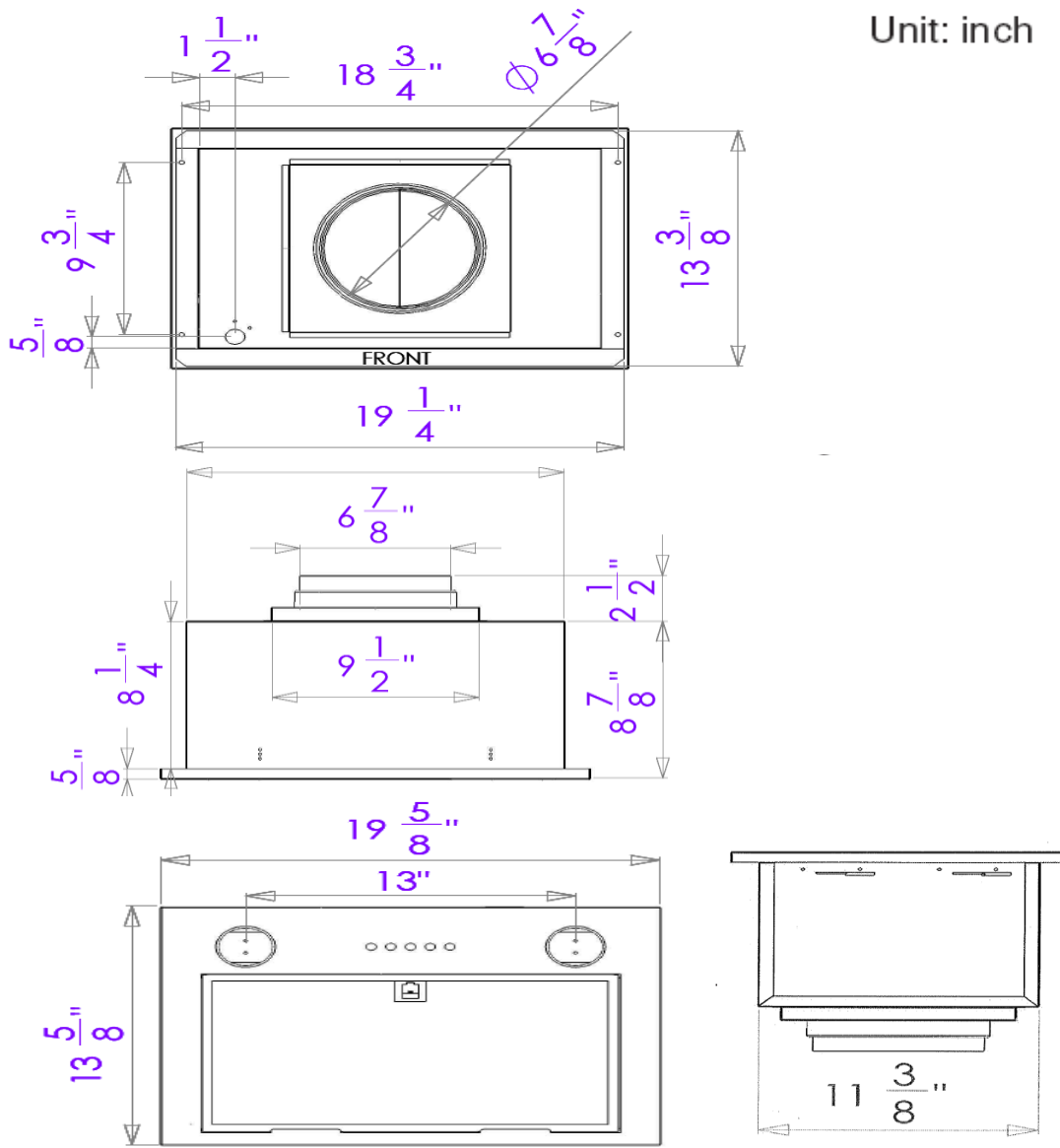



# CONSIGNES DE SÉCURITÉ

Avant l'installation et le fonctionnement, lire attentivement ces instructions et utiliser ce produit uniquement de la manière décrite par le fabricant dans le manuel d'utilisation. Les instructions ci-dessous sont utilisés pour vous avertir des risques de blessure corporelle potentiel correctement et risques de dommages.

Il y a trois classifications de risques en fonction de situations potentiellement dangereuses. Respectez toutes les consignes de sécurité qui montrent ces symboles pour éviter les risques de blessures, de décès et de dommages matériels.

 **D'AVERTISSEMENT:** d'avertissement indique une situation potentiellement dangereuse qui, si elle n'est pas évitée, pourrait entraîner la mort ou des blessures graves.

 **AVERTIR:** avertir indique une situation potentiellement dangereuse qui, si elle n'est pas évitée, peut entraîner des blessures mineures ou modérées.



 **AVERTIR:** avertir indique utilisé sans le symbole d'alerte de sécurité indique une situation potentiellement dangereuse qui, si elle n'est pas évitée, peut entraîner des dommages à la propriété.

*NOTE: Les consignes de sécurité sont expliquées dans la suite symboles pictographiques.*

 **signifie interdiction.** Il indique les actions, le cas échéant, qu'il ne faut pas faire.

 **signifie exécution forcée.** Il indique que des actions, le cas échéant, qui doit être fait.

## **D'AVERTISSEMENT**

-  **1. POUR RÉDUIRE LE RISQUE D'INCENDIE, choc électronique, ou des blessures à des personnes, OBSERVER LES POINTS SUIVANTS:**
  - Utilisez cet appareil uniquement de la manière indiquée par le fabricant. Si vous avez des questions, contactez le fabricant.
  - Avant de procéder à l'entretien ou le nettoyage de l'appareil, couper l'alimentation électrique au panneau de service et verrouillez le service moyen de coupure pour empêcher le courant de mise en marche automatiquement. Lorsque le service moyen de coupure ne peut pas être verrouillé, fixer solidement un important dispositif d'alerte, comme une balise, au panneau de service.
-  **2. Pour réduire le risque d'incendie ou de choc électrique, n'utilisez pas ce produit avec tout état solide dispositif de contrôle de vitesse.**
-  **3. POUR RÉDUIRE LE RISQUE D'INCENDIE, DE CHOC ÉLECTRIQUE OU DES BLESSURES AUX PERSONNES, OBSERVER LES POINTS SUIVANTS:**
  - Travaux d'installation et le câblage électrique doit être effectué par une personne qualifiée(s) conformément à tous

les codes et les normes applicables, y compris au feu de la construction

- Suffisamment d'air est nécessaire pour une bonne combustion et épuisant des gaz à travers les gaz de combustion (cheminée) de la combustion du fabricant du matériel des directives et normes de sécurité telles que celles publiées par la National Fire Protection Association (NFPA), et l'American Society for Heating, Refrigeration and Air Conditioning Engineers (ASHRAE), et les autorités du code.
  - Lors de coupe ou de perçage dans le mur ou le plafond, ne pas endommager le câblage électrique et autres utilitaires masqués.
  - Canalisées le ventilateur doit toujours être évacué à l'extérieur.
- 4. POUR RÉDUIRE LE RISQUE D'INCENDIE, N'UTILISEZ QUE LES GAINES métalliques.**
  - Cette unité doit être mise à la terre.
  - Vérifier que le capot est correctement installé, car une mauvaise installation pourrait entraîner dans la gamme du capot se détacher et tomber.
  - Se connecter uniquement à un AC120 v source d'alimentation ou le capot gamme pourrait entraîner un incendie, un choc électrique ou de dommages.

## **AVERTIR**

- Pour ventilation générale utilisation uniquement. Ne pas utiliser d'échappement dangereux ou matières explosives et les vapeurs.
- Pour réduire le risque d'incendie et d'échappement d'air, assurez-vous de conduit d'air extérieur. Ne pas évacuer l'air d'échappement à l'intérieur des murs, plafonds ou dans les greniers, et les garages.
- Lire étiquette de spécification sur ce produit pour de plus amples informations et les exigences.
- Utilisez uniquement à des fins de ventilation cuisine.
- N'installez pas cette gamme capot dans la salle de bains ou dans d'autres salles humides depuis choc électrique et risque de l'endommager.
- Fixer le filtre et les autres pièces solidement. Fixation incorrecte peut entraîner des blessures ou des dommages matériels.
- Gardez les mains et autres objets à l'écart du ventilateur pendant qu'elle est en mouvement. La plage du capot peut vous blesser ou le dommage lui-même.



# PRÉPARATION



## D'AVERTISSEMENT:

- Si la plage capot n'est pas installé correctement, il pourrait se détacher et tomber.
- S'assurer que le conduit métallique ne touche pas d'autres logements métalliques matériaux, sinon un incendie ou un choc électrique pourrait entraîner.

1. Selon les conditions où la plage du capot est installé, déterminer si elle se décharge verticalement ou horizontalement (7" autour de conduit). Vertical ou horizontal décharge, exécutez travail conduit entre le capot emplacement et une casquette de toit ou mur pac. Pour le meilleur résultat dans un sens ou dans l'autre, utilisez un nombre minimum de transitions et les coudes. Assurez-vous de joindre un toit ou un mur le bouchon pour éviter toute fuite d'eau.

2. La gamme de capot doit être monté sur une chemise qui a des dimensions. Installez la chemise solidement après avoir vérifié que la taille de l'ouverture de la chemise est la même que la figure ci-dessous.

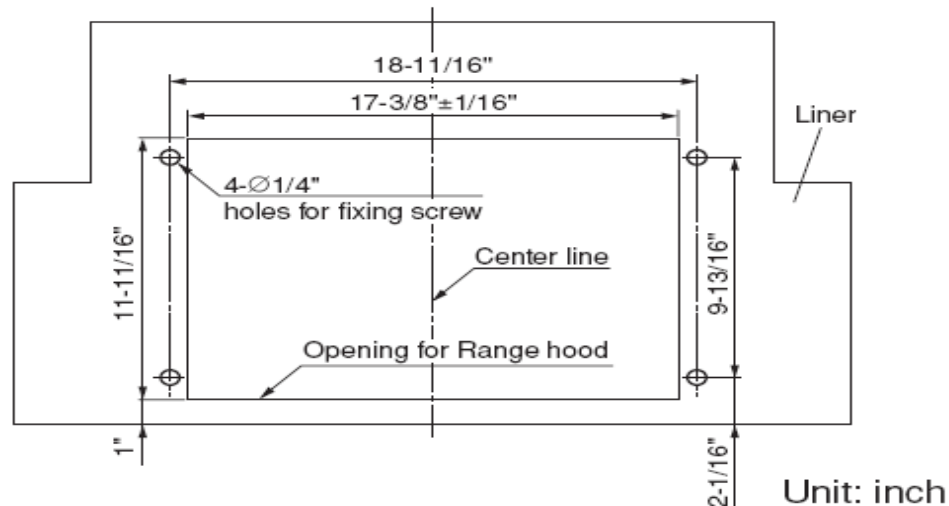
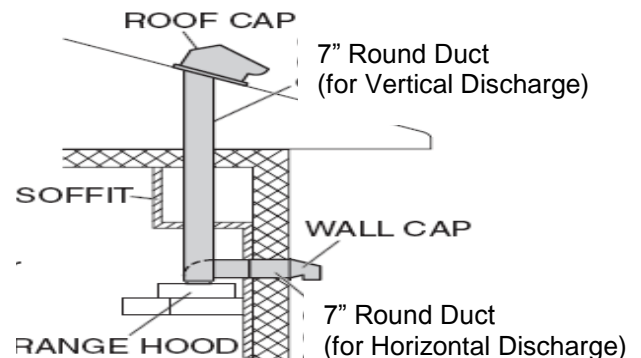

## AVERTIR:

- La chemise doit être installé correctement. Si la pose de la chemise n'est pas correcte, la gamme capot unité peut se détacher et tomber.



## D'AVERTISSEMENT – POUR RÉDUIRE LE RISQUE D'UNE GAMME HAUT FEU DE GRAISSE:

- a) Ne jamais laisser unités de surface sans surveillance à paramètres élevés. Boilovers cause fumeur et retombées grasse qui peuvent s'enflammer. Chauffer lentement les huiles de faible ou moyenne paramètres.
- b) Mettez toujours le capot lors de la cuisson à température élevée ou lorsque flambéing alimentaire ( c'est-à-dire Crêpes Suzette, cerises Jubilé, boeuf au poivre flambés).
- c) Nettoyer ventilation ventilateurs fréquemment. La graisse ne doit être autorisé à s'accumuler sur le ventilateur ou le filtre.
- d) Utiliser la taille du carter. Toujours utiliser vaisselle appropriées à la taille de l'élément surface.



## CONNECTER LE TUYAU D'ÉVENT

Le 011/021 Série ventilation modules viennent avec un métal démarrer le collier. Fixer le début le collier pour le conduit avec au moins trois également espacés vis. Aussi s'appliquer du ruban adhésif, de préférence du type métallique. Certaines installations, (où le dehors de la position du conduit est non accessible) exigera la bande métallique sera appliqué à l'intérieur du conduit.

## SPECIFICATION SHEET - 011

011 VMI, Inc. Blower unit, Individual Specifications Dated April 10, 2013

<b>Model</b>	<b>011 Stainless Steel Front Cover Panel*</b>
<b>Safety Standards</b>	C-UL-US Listed
<b>Dimensions</b>	
Front Panel	13 3/4" Deep x 19 3/4" Wide
Housing	11 3/8" Deep x 17 3/8" Wide x 8 1/4" High (with Damper, 10 3/4" High)
<b>Weight</b>	18 lbs
<b>Rated Voltage</b>	120 Volts
<b>Rated Frequency</b>	60 Hz
<b>Air Flow</b>	High Speed Operating 290 CFM Medium Speed Operating 210 CFM Low Speed Operating 150 CFM
<b>Noise Level</b>	High Speed Motor 7 Sones Medium Speed Motor 5 Sones Low Speed Motor 3 Sones
<b>Power Consumption</b>	High Speed 120 Watts
<b>Motor Only</b>	Medium Speed 90 Watts Low Speed 60 Watts
<b>Electric Motor</b>	Capacitor Motor, 3 Speeds
<b>Duct Dimension</b>	7" Round Duct
<b>Exhaust Direction</b>	Vertical Discharge from top, Horizontal with Elbow
<b>Installation</b>	At 4 places on flange of body, use screws and nut plates for mounting to Liner
<b>Materials</b>	Front Cover Panel - 304 Grade Stainless Steel, # 4 Brush Finish Housing Body - Electro-Galvanized steel Filters - Aluminum Mesh *Front Cover Panel Colors -Silver Metallic, White, Bisquit, Black
<b>Lighting</b>	(2) 50 watt MR16-GU10 Halogen Lamps
<b>Switches</b>	Mechanical Push Button 3 Speed with Off Motor Control Mechanical Push Button Light Control
<b>Electrical Wiring</b>	PVC, 18 AWG
<b>Accessories</b>	Damper, Nut Plates with screws
<b>Optional Parts</b>	Metal Liners, Rectangular, T-Shaped, Custom Sized
<b>Manual</b>	Installation/Operation Manual

## SPECIFICATION SHEET - 021

021 VMI, Inc. Blower unit, Individual Specifications Dated April 10, 2013

<b>Model</b>	<b>021 Stainless Steel Front Cover Panel*</b>
<b>Safety Standards</b>	C-UL-US Listed
<b>Dimensions</b>	
Front Panel	13 3/4" Deep x 19 3/4" Wide
Housing	11 3/8" Deep x 17 3/8" Wide x 8 1/4" High (with Damper, 10 3/4" High)
<b>Weight</b>	18 lbs
<b>Rated Voltage</b>	120 Volts
<b>Rated Frequency</b>	60 Hz
<b>Air Flow</b>	High Speed Operating 390 CFM Medium Speed Operating 290 CFM Low Speed Operating 180 CFM
<b>Noise Level</b>	High Speed Motor 7 Sones Medium Speed Motor 5 Sones Low Speed Motor 3 Sones
<b>Power Consumption</b>	High Speed 120 Watts
<b>Motor Only</b>	Medium Speed 90 Watts Low Speed 60 Watts
<b>Electric Motor</b>	Capacitor Motor, 3 Speeds
<b>Duct Dimension</b>	7" Round Duct
<b>Exhaust Direction</b>	Vertical Discharge from top, Horizontal with Elbow
<b>Installation</b>	At 4 places on flange of body, use screws and nut plates for mounting to Liner
<b>Materials</b>	Front Cover Panel - 304 Grade Stainless Steel, # 4 Brush Finish Housing Body - Electro-Galvanized steel Filters - Aluminum Mesh *Front Cover Panel Colors - Silver Metallic, White, Bisquit, Black
<b>Lighting</b>	(2) 50 watt MR16-GU10 Halogen Lamps
<b>Switches</b>	Mechanical Push Button 3 Speed with Off Motor Control Mechanical Push Button Light Control
<b>Electrical Wiring</b>	PVC, 18 AWG
<b>Accessories</b>	Damper, Nut Plates with screws
<b>Optional Parts</b>	Metal Liners, Rectangular, T-Shaped, Custom Sized
<b>Manual</b>	Installation/Operation Manual

# UTILISATION ET ENTRETIEN



## D'AVERTISSEMENT!

NE PAS faire fonctionner le ventilateur/le ventilateur système sans les filtres en place, ou avec sale, graisse laden filtres.



## CONTRÔLES DE FONCTIONNEMENT:

Toujours activer le ventilateur ou lorsque vous utilisez les appareils. Pour des performances optimales, mettez le ventilateur quelques minutes avant de commencer à cuisiner pour établir un modèle d'air dans la salle. Régler la vitesse du ventilateur selon le besoin. La commande gauche ajuste l'éclairage halogène et le droit de contrôle ajuste le ventilateur.



## CONSEILS EN MATIÈRE D'ÉCONOMIES D'ÉNERGIE:

Éliminer les courants d'air dans les environs par l'arrêt à proximité les portes et les fenêtres, éteindre les ventilateurs de plafond et de réglage du côté chauffage et climatisation prises si nécessaire. Placez votre plus grande casseroles sur les brûleurs arrière chaque fois que possible. Nettoyer les filtres et la graisse laden surfaces souvent à améliorer l'efficacité. Utilisez toujours les couvercles sur vaisselle pour conserver la chaleur et de l'humidité. Minimiser la quantité de liquide utilisée pour cuire les aliments.



## SOINS & NETTOYAGE:

Un bon nettoyage est nécessaire afin de maintenir les performances et l'apparence, tout en assurant une sécurité de fonctionnement. La fréquence de nettoyage devrait être selon le type et la quantité de la cuisson. Les meilleurs résultats seront obtenus par nettoyage sale composants dès que possible. Les filtres doivent être nettoyés régulièrement. Déposer le(s) filtre(s) en saisissant l'anneau en D sur l'avant du filtre et en tirant doucement. Saisissez l'avant du filtre pour le retirer.

Les filtres peuvent être nettoyés à la main dans de l'eau chaude avec un détergent doux ou en le plaçant dans un lave-vaisselle automatique. Sécher le filtre avant de le réutiliser.

**Avertir:** La plupart laveur commun type plaquettes de rayer la chemise. Si un commercialement disponible nettoyant pour acier inoxydable est utilisé, il est important de lire les étiquettes de composés du chlore. Le chlore est une substance corrosive. Si ces composés sont présents, bien rincer et sécher avec un chiffon doux non pelucheux. Suivez polonais les instructions du fabricant. Essuyez toujours en acier inoxydable surfaces avec le grain. Essuyez jamais en travers du grain. Après nettoyage, remettre en place les filtres avec précaution.



## AMPOULES HALOGÈNES:

Ventilateurs sont conçus pour MR16-GU10 50 watts lampes halogènes. Ils peuvent être achetés à la maison ou les épicerie, p. ex., Lowe's, Home Depot, McCoy's, Menards ou Ace valeur vraie.

## RACCORDEMENT ÉLECTRIQUE

**IMPORTANT: Copiez cette page et la suivante pour votre installation électrique.**



**D'AVERTISSEMENT!** S'assurer que le bloc d'alimentation est débranché avant de continuer. Vérifiez que la tension d'alimentation correspond à la cote trouvé sur l'appareil étiquette de données avant de poursuivre. L'appareil doit être correctement mis à la terre en tout temps lorsque l'alimentation électrique est appliqué. Ne pas mettre à la masse l'appareil avec le neutre (blanc) chambre fil d'alimentation. Un fil de masse séparé doit être utilisé. Échec de connexions électriques correctement peut endommager ou non systèmes fonctionnels.

Il relève de la responsabilité du propriétaire de s'assurer qu'une personne qualifiée effectue la connexion électrique de l'appareil. L'installation électrique, y compris d'alimentation minimum taille de fil, doivent se conformer au Code électrique national ANSI/NFPA 70-1990 (ou dernière révision) et les codes et décrets locaux. Une copie de cette norme peuvent être obtenus auprès de: National Fire Protection Association, 1 Batterymarch Park, Quincy, Massachusetts 02269-9101.

**MODE D'EMPLOI:** Un service 15 to 20 ampères électrique est recommandé pour l'alimentation électrique appropriée. Avant de déterminer, calculer les cotes ampères sur la base de l'étiquette du produit disponible sur le module de 011/021 série. Toujours respecter les codes du bâtiment locaux. Toujours utiliser un circuit dédié. Charge linéaire est calculée en additionnant l'intensité de l'éclairage halogène à l'intensité nominale du ventilateur. Si le ventilateur est en watts plutôt que ampères, diviser les watts par 120 et cela vous donnera l'ampérage.





**AVERTIR:** Le fil neutre (généralement blanc) pour le ventilateur doit se connecter sur le même fil neutre qui provient du panneau électrique de la chemise.

### Installé en usine à régime variable détails de câblage

Noir	120 Volts AC de panneau électrique (généralement le noir)
Blanc	Position neutre du panneau électrique (blanc)
Vert	La masse de panneau électrique (généralement en vert)

## SCHÉMA de CÂBLAGE

### 011/021 Series Models

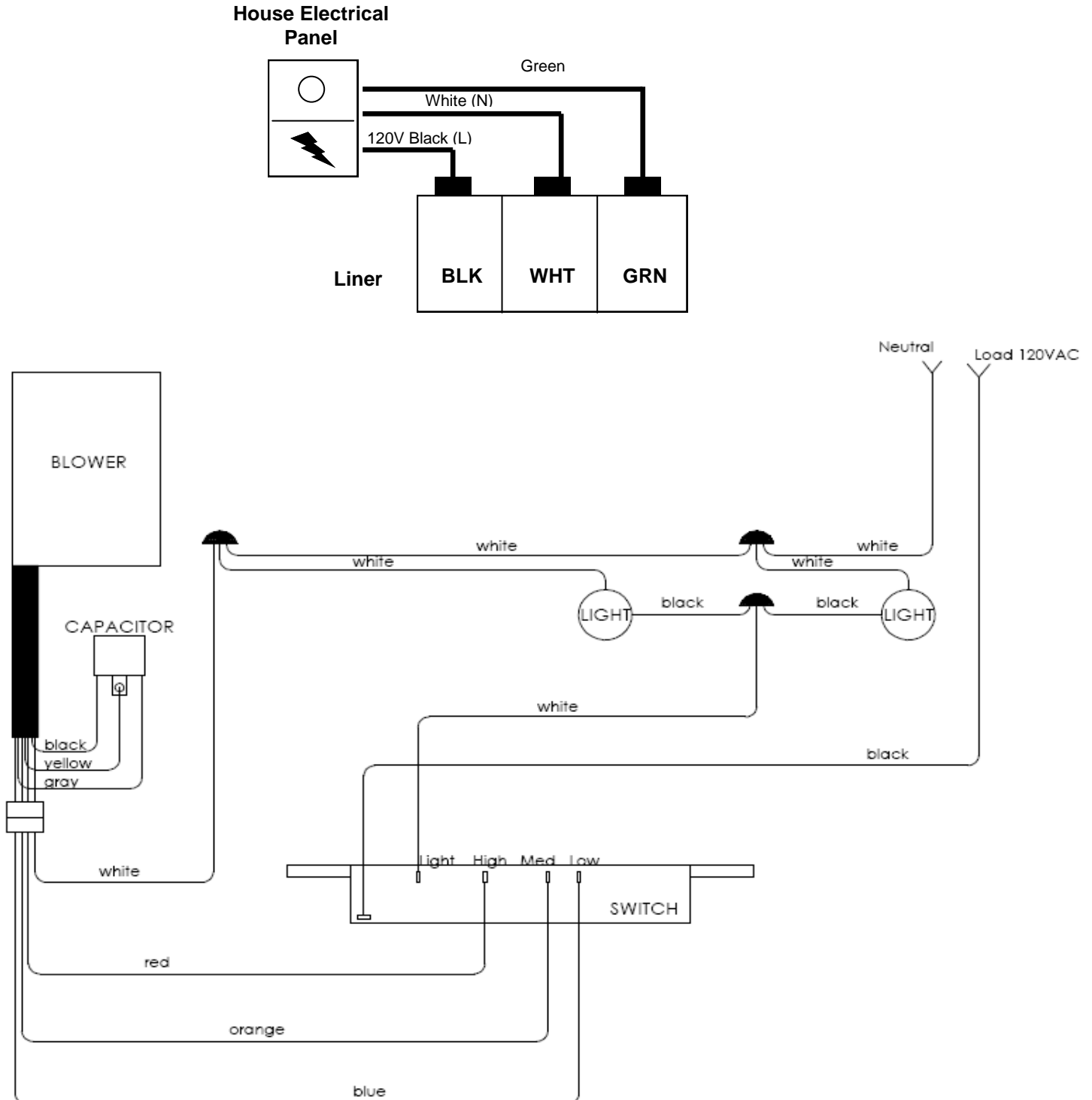



## WARRANTY

### Air-Pro™ Brand Ventilation Products

#### What is Covered

VMI Inc. warrants its Air-Pro™ brand products to the original user, to be free of defects in materials and workmanship for three (3) years from the date of purchase.

VMI Inc., at its option, will repair or replace the complete unit or any defective component without charge providing that, if requested, the product or defective component is promptly returned, prepaid to the address below. This warranty may be voided if any unauthorized service, alterations or repairs are made to the product.

#### What is Not Covered

- Normal maintenance and service of any product that has been subject to misuse, negligence, accident or installation inconsistent with the recommended installation instructions
- Product used other than for normal in-home use or products used outside of the United States and Canada.
- Damage to the product caused by accident, fire, flood or other acts of God.
- Service calls to educate the customer in the proper use and care of the product, correct faulty installation, change fuses or reset breakers.

VMI Inc. disclaims and excludes any liability for implied warranties or for incidental or consequential damages wherever permitted by law. There are no implied warranties of merchantability or fitness for a particular use or purpose. This warranty gives you specific legal rights and you may also have other rights, which vary from state to state.

#### For Service

If you need service, contact Customer Service at the address or phone number below. Provide the model number, part identification and details of the problem. Proof of purchase must be provided.



VMI Inc.  
P.O. Box 2765 • Redmond, WA 98073  
Phone: 206-835-9880 • Fax: 206-835-9876  
[www.vmi-inc.net](http://www.vmi-inc.net)



Rev. 04/13

VMI, Inc.  
P.O. Box 2765  
Redmond, WA 98073  
Toll Free: 1-888-547-9880  
Phone: 206-835-9880 \*\*\*\* Fax: 206-835-9876